

SM-170R

Industrial monitor, 17" True-Flat Industrial Grade 5-Wire Resistive Touch



Features

- 17 inches SXGA LCD with LED backlight, front panel support IP66
- Aluminum alloy structure makes it lighter, more stable, and better heat dissipation
- Industrial-grade 5-Wire Resistive Touch
- 12 DC-IN, lockable Phoenix connector
- Support standard VESA and panel mount



HDMI



-10~60°C

LCD Display

Size/Type	17 inches TFT LCD Panel
Max. Resolution	1280(H) x 1024(V)
Ratio	4:3
Luminance	250 nits
Contrast Ratio	1000:1
Backlight Type	LED
Backlight Lifetime	50,000 Hrs
Touch Type	Industrial-grade 5-Wire Resistive Touch
Touch	35,000,000 times
View Angle	CR ≥ 10; θx 170°(H)/ θy 160°(V) CR ≥ 5; θx 178°(H)/ θy 170°(V)

External I/O

USB Ports	1 x USB for Touch
Video Ports	1 x HDMI
	1 x VGA
	1 X DVI

Power Requirement

Power Input	12V DC-IN by 2-pin Phoenix connector
-------------	--------------------------------------

Mechanical

Front Panel	Aluminum alloy
Rear Cover	SECC
Dimension	392.4 x 327.7 x 44 mm
Cut-Out	382.2 x 317.5 mm
Mounting	Panel Mount, Wall and VESA-mount
Weight	4 Kg
Ingress Protection	Front Panel IP66

OSD Menu

ON/OFF	Power On/Off
MENU	Menu / Confirm
Auto	Signal input switch / Quit
+	Up / Increase
-	Down / Decrease

Environmental

Operating Temp.	-10 ~ 60°C (14 ~ 140°F), ambient w/ air flow
Storage Temp.	-40 ~ 70°C (-40 ~ 158°F)
Operating Humidity	5 ~ 95% @ 40°C (non-condensing)
Vibration	5 ~ 500Hz, 2Grms operation
Shock	Operation: 10G@11ms
	Non-operation: 30G@11ms

Dimension

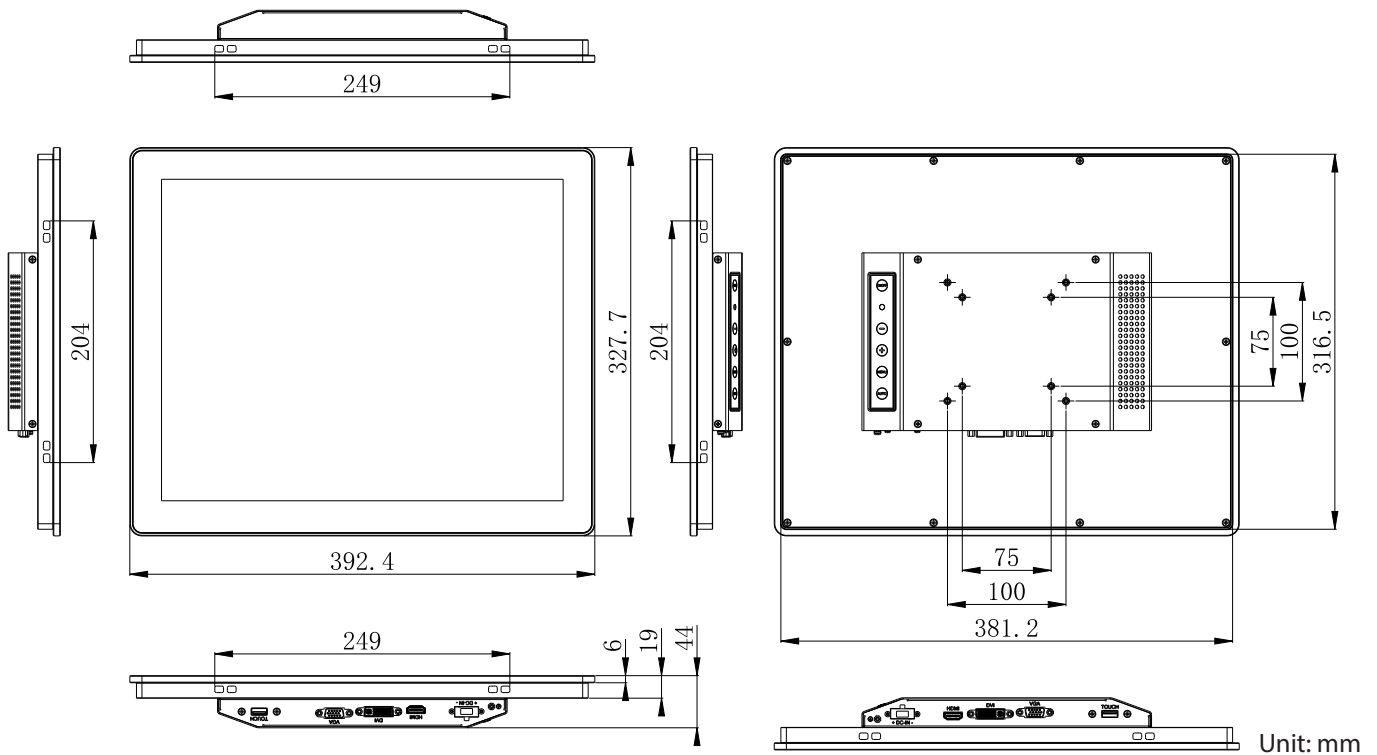

Ordering Information

SM-170R 17" (4:3) Industrial Touch Monitor, 5-Wire Resistive Touch

Standard Accessories

Panel Hook (4pcs in 1 Package)	2 packages
2-pin DC-in Phoenix connector	1 pcs
VGA Cable	1 pcs
USB Cable	1 pcs
Screw package for VESA	1 package

Optional Accessories

PAC-60W-FSP-SPA-US R1.0	AC/DC Adapter Kit (w/ UKCA), 12V, 60W, 2 WIRE w/ US POWER CORD
PAC-60W-FSP-SPA-EU R1.0	AC/DC Adapter Kit (w/ UKCA), 12V, 60W, 2 WIRE w/ EU POWER CORD
PAC-60W-FSP-SPA-UK R1.0	AC/DC Adapter Kit (w/ UKCA), 12V, 60W, 2 WIRE w/ UK POWER CORD
PAC-60W-FSP-SPA-IN R1.0	AC/DC Adapter Kit (w/ UKCA), 12V, 60W, 2 WIRE w/ IN POWER CORD
PAC-60W-FSP-SPA-JP R1.0	AC/DC Adapter Kit (w/ UKCA), 12V, 60W, 2 WIRE w/ JP POWER CORD